

Product catalouge stainless



Electric pallet stacker

SBE/SR 90 Capacity 1500kg
Stainless

Walsted Truck A/S

Flexible solutions

- Two wheel drive
- Power steering
- With or without side guards / stand-in
- With or without stand-on platform
- Can also be supplied in Painted versions



SBE/SR 90 Specifications

Walsted Truck A/S

Flexible solutions

Stainless

Typ			SBE/SR 90
Capacity	Q Load , Loadcenter 600 mm	kg	1500
Power type	Electric (battery)		Battery
Type of steering	Electric power steering		
Forkwheels	Numbers / type V = Vulkollan		(2 or 4x) V
Drivingwheels	Numbers / type V = Vulkollan		(2x) V
Turning radius	Wa (without platform)	mm	1561
Turning radius	Wa (with platform)	mm	2001
Aisle width	AST with pallet 800 x 1200 (without platform)	mm	2253
Aisle width	AST with pallet 800 x 1200 (with platform)	mm	2693
Speed	Driving speed without/with load	km/h	6/5,4- (11,5/8,5**)
Grade ability	Without/with load	%	10/10
Weight	Without battery	kg	950
Brakes	Type		Electric
Battery	Type		Reinforced
	Capacity by 5 hours	V/Ah	24/344
	Weight approx.	kg	262
Electric motor	drivemotor power/S2 min.	KW/min.	2x1,5/60
	Pump motor power/S3	KW/%.	3/-
Speed control	Type		Stepless
Lifting / lowering control	Electric		Stepless

** with side-guards

Masttype	h =Building-height, mast (mm)	h1 = lift (mm)	h2=Buildingheight by max lift (mm)	Free lift (mm)	Capacity by 600mm L/C (kg)
Simplex	2370	2000	2395	1975	1500
Duplex	2210	3500	3895	186	1000
	1960	3000	3395	186	1250
	1710	2500	2895	186	1500
	1460	2000	2395	186	1500

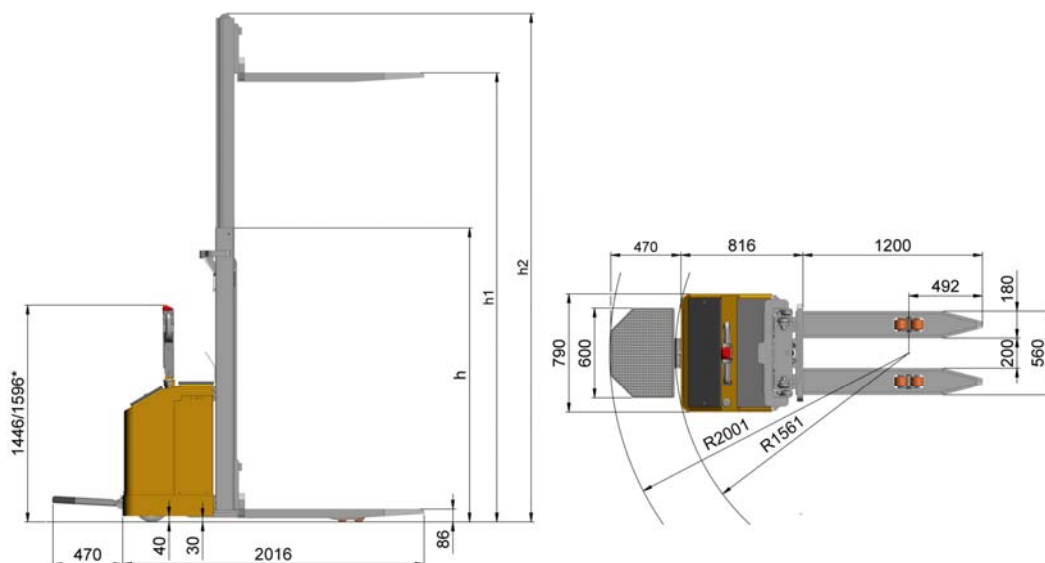

These specifications are subject to change without notice

*without platform

Electric pallet stacker

SBE/SR FF 90 Capacity 1500kg
Stainless, full freelif

Walsted Truck A/S

Flexible solutions

- Two wheel drive
- Power steering
- With or without side guards / stand-in
- With or without stand-on platform
- Can also be supplied in painted versions



SBE/SR FF 90 Specifications

Walsted Truck A/S

Stainless

Flexible solutions

Typ			SBE/SR 90 FF
Capacity	Q Load , Loadcenter 600 mm	kg	1500
Power type	Electric (battery)		Battery
Type of steering	Electric power steering		
Forkwheels	Numbers / type V = Vulkollan		(2 or 4x) V
Drivingwheels	Numbers / type V = Vulkollan		(2x) V
Turning radius	Wa (without platform)	mm	1561
Turning radius	Wa (with platform)	mm	2001
Aisle width	AST with pallet 800 x 1200 (without platform)	mm	2253
Aisle width	AST with pallet 800 x 1200 (with platform)	mm	2693
Speed	Driving speed without/with load	km/h	6/5,4-(11,5/8,5**)
Grade ability	Without/with load	%	10/10
Weight	Without battery	kg	950
Brakes	Type		Electric
Battery	Type		Reinforced
	Capacity by 5 hours	V/Ah	24/344
	Weight approx.	kg	262
Electric motor	drivemotor power/S2 min.	KW/min.	2x1,5/60
	Pump motor power/S3	KW/%.	3/-
Speed control	Type		Stepless
Lifting / lowering control	Electric		Stepless

** with side-guards

Masttype	h =Building-height, mast (mm)	h1 = lift (mm)	h2=Buildingheight by max lift (mm)	Free lift (mm)	Capacity by 600mm L/C (kg)
Duplex	2235	3500	3895	1840	1000
	1985	3000	3395	1590	1250
	1735	2500	2895	1340	1500
	1485	2000	2395	1090	1500

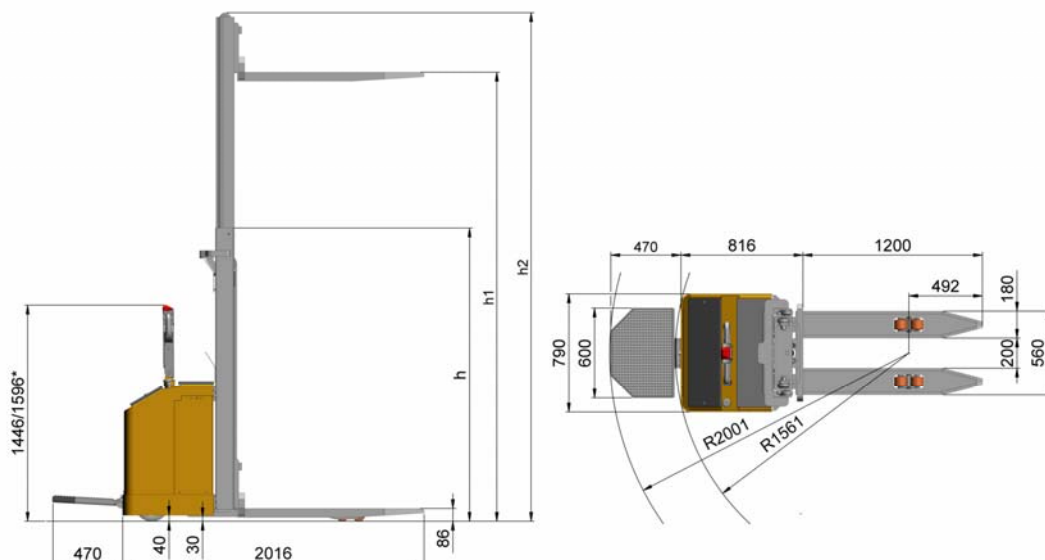

These specifications are subject to change without notice

*without platform

Electric pallet stacker

SBE/SR 90 Capacity 1500kg
Stainless, Triplex

Walsted Truck A/S

Flexible solutions

- Two wheel drive
- Power steering
- With or without side guards / stand-in
- With or without stand-on platform
- Can also be supplied in Painted versions



SBE/SR 90 T Specifications

Stainless, Triplex

Walsted Truck A/S

Flexible solutions

Typ			SBE/SR 90 T
Capacity	Q Load , Loadcenter 600 mm	kg	1500
Power type	Electric (battery)		Battery
Type of steering	Electric power steering		
Forkwheels	Numbers / type V = Vulkollan		(2 or 4x) V
Drivingwheels	Numbers / type V = Vulkollan		(2x) V
Turning radius	Wa (without platform)	mm	1561
Turning radius	Wa (with platform)	mm	2001
Aisle width	AST with pallet 800 x 1200 (without platform)	mm	2253
Aisle width	AST with pallet 800 x 1200 (with platform)	mm	2693
Speed	Driving speed without/with load	km/h	6/5,4- (11,5/8,5**)
Grade ability	Without/with load	%	10/10
Weight	Without battery	kg	950
Brakes	Type		Electric
Battery	Type		Reinforced
	Capacity by 5 hours	V/Ah	24/344
	Weight approx.	kg	262
Electric motor	drivemotor power/S2 min.	KW/min.	2x1,5/60
	Pump motor power/S3	KW/%.	3/-
Speed control	Type		Stepless
Lifting / lowering control	Electric		Stepless

** with side-guards

Masttype	h =Building-height, mast (mm)	h1 = lift (mm)	h2=Buildingheight by max lift (mm)	Free lift (mm)	Capacity by 600mm L/C (kg)
Triplex	1716	3500	3897	1264	1200
	1882	4000	4397	1430	800
	1949	4200	4597	1497	750
	2016	4400	4797	1564	700

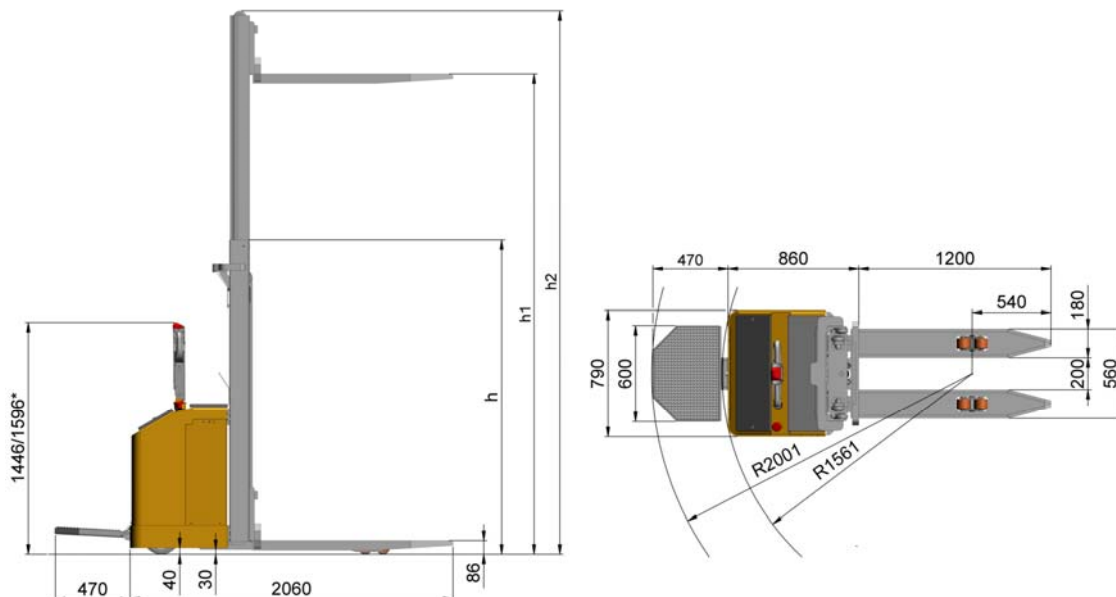

These specifications are subject to change without notice

*without platform

Electric pallet stacker

SBE/SR 80 Capacity 1500kg
Stainless, Triplex

Walsted Truck A/S

Flexible solutions

- Two wheel drive
- Power steering
- With or without side guards / stand-in
- With or without stand-on platform
- Can also be supplied in painted versions



SBE/SR 80 T Specifications

Stainless, Triplex

Walsted Truck A/S

Flexible solutions

Typ			SBE/SR 80 T
Capacity	Q Load , Loadcenter 600 mm	kg	1500
Power type	Electric (battery)		Battery
Type of steering	Electric power steering		
Forkwheels	Numbers / type V = Vulkollan		(2 or 4x) V
Drivingwheels	Numbers / type V = Vulkollan		(2x) V
Turning radius	Wa (without platform)	mm	1561
Turning radius	Wa (with platform)	mm	2001
Aisle width	AST with pallet 800 x 1200 (without platform)	mm	2253
Aisle width	AST with pallet 800 x 1200 (with platform)	mm	2693
Speed	Driving speed without/with load	km/h	6/5,4-(11,5/8,5**)
Grade ability	Without/with load	%	10/10
Weight	Without battery	kg	950
Brakes	Type		Electric
Battery	Type		Reinforced
	Capacity by 5 hours	V/Ah	24/344
	Weight approx.	kg	262
Electric motor	drivemotor power/S2 min.	KW/min.	2x1,5/60
	Pump motor power/S3	KW/%.	3/-
Speed control	Type		Stepless
Lifting / lowering control	Electric		Stepless

** with side-guards

Masttype	h =Building-height, mast (mm)	h1 = lift (mm)	h2=Buildingheight by max lift (mm)	Free lift (mm)	Capacity by 600mm L/C (kg)
Triplex	1716	3500	3897	1264	1250
	1882	4000	4397	1430	1100
	1949	4200	4597	1497	1050
	2016	4400	4797	1564	1000

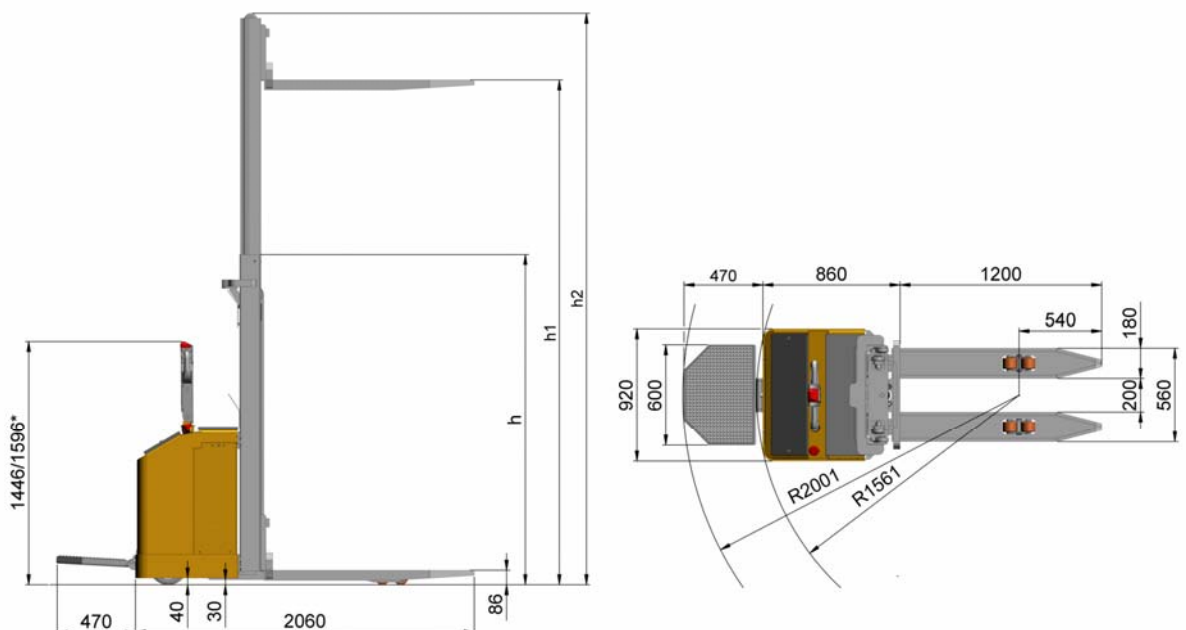

These specifications are subject to change without notice

*without platform

Electric pallet stacker

SBE/SIR 92 Capacity 1500kg
Stainless

Walsted Truck A/S

Flexible solutions

- Two wheel drive
- Power steering
- With or without side guards / stand-in
- With or without stand-on platform
- Can also be supplied in painted versions



SBE/SIR 92 Specifications

Walsted Truck A/S

Flexible solutions

Type			SBE/SIR 92
Max lifting load	Total load on forks + Basislift	kg	2000
Capacity, forks	Q load by 600mm loadcenter	kg	1500
Capacity, basislift		kg	2000
Liftingheight, basislift	Up to 2500mm lift	mm	200
Power type	Electric (battery)		Battery
Type of steering	Electric power steering		
Forkwheels	Numbers / type V = Vulkollan		(4x) / V
Drivingwheels	Numbers / type V = Vulkollan		(2x) / V
Turning radius	Wa (without platform)	mm	1674
Turning radius	Wa (with platform)	mm	2115
Aisle width	AST with pallet 800 x 1200 (without platform)	mm	2366
Aisle width	AST with pallet 800 x 1200 (with platform)	mm	2807
Speed	Driving speed without/with load	km/h	6/5,4-(11,5/8,5**)
Grade ability	Without/with load	%	10/10
Weight	Without battery	kg	1150
Brakes	Type		Electric
Battery	Type		Reinforced
	Capacity by 5 hours	V/Ah	24/344
	Weight approx.	kg	262
Electric motors	Drivemotor power/S2 min.	KW/min.	2x1,5/60
	Pump motor power/S3	KW/%.	3/-
Speed control			Stepless
Lifting / lowering control	Electric		Stepless

** With side-guards

Masttype	h =Building-height (mm)	h1 = lift (mm)	h2=Buildingheight by max lift (mm)	Freelift (mm)	Capacity by 600mm L/C(kg)
Simplex	2370	2000	2395	1975	1500
Duplex	2210	3500	3895	186	1000
	1960	3000	3395	186	1250
	1710	2500	2895	186	1500
	1460	2000	2395	186	1500

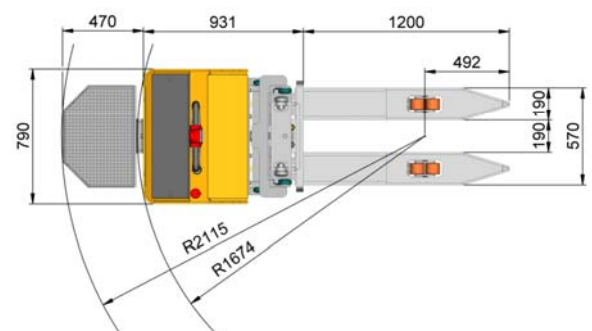
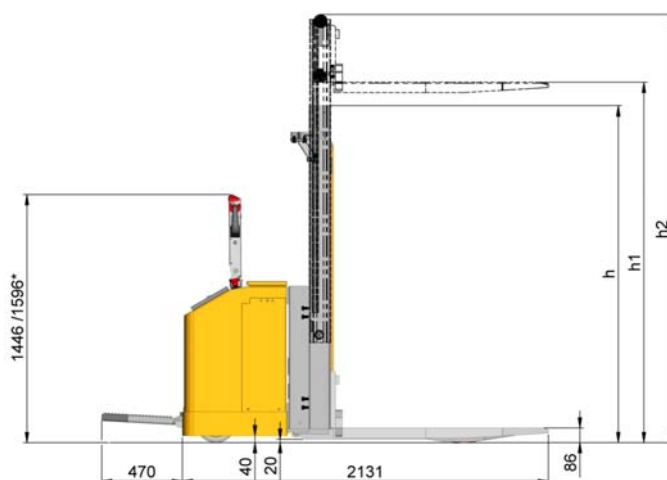

*Without platform

These specifications are subject to change without notice

Electric pallet stacker

SBE/SIR 92 FF Capacity 1500kg
Stainless

Walsted Truck A/S

Flexible solutions

- Two wheel drive
- Power steering
- With or without side guards / stand-in
- With or without stand-on platform
- Can also be supplied in painted versions

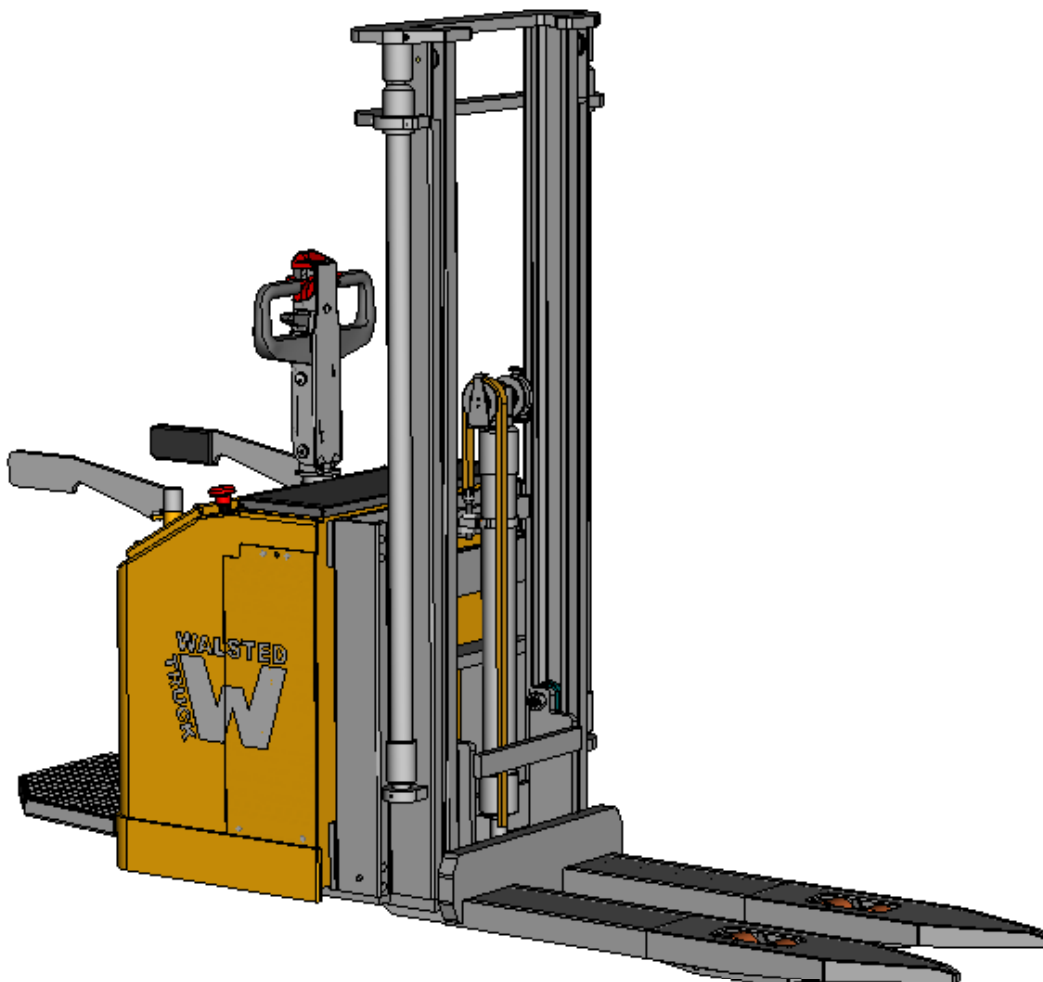

SBE/SIR 92 FF Specifications

Walsted Truck A/S

Stainless

Flexible solutions

Type			SBE/SIR 92
Max lifting load	Total load on forks + Basislift	kg	2000
Capacity, forks	Q load by 600mm loadcenter	kg	1500
Capacity, basislift		kg	2000
Liftingheight, basislift	Up to 2500mm lift	mm	200
Power type	Electric (battery)		Battery
Type of steering	Electric power steering		
Forkwheels	Numbers / type V = Vulkollan		(4x) / V
Drivingwheels	Numbers / type V = Vulkollan		(2x) / V
Turning radius	Wa (without platform)	mm	1674
Turning radius	Wa (with platform)	mm	2115
Aisle width	AST with pallet 800 x 1200 (without platform)	mm	2366
Aisle width	AST with pallet 800 x 1200 (with platform)	mm	2807
Speed	Driving speed without/with load	km/h	6/5,4-(11,5/8,5**)
Grade ability	Without/with load	%	10/10
Weight	Without battery	kg	1150
Brakes	Type		Electric
Battery	Type		Reinforced
	Capacity by 5 hours	V/Ah	24/344
	Weight approx.	kg	262
Electric motors	Drivemotor power/S2 min.	KW/min.	2x1,5/60
	Pump motor power/S3	KW/%.	3/-
Speed control			Stepless
Lifting / lowering control	Electric		Stepless

** With side-guards

Masttype	h =Building-height (mm)	h1 = lift (mm)	h2=Buildingheight by max lift (mm)	Freelift (mm)	Capacity by 600mm L/C(kg)
Duplex	2235	3500	3895	1840	1000
	1985	3000	3395	1590	1250
	1735	2500	2895	1340	1500
	1485	2000	2395	1090	1500

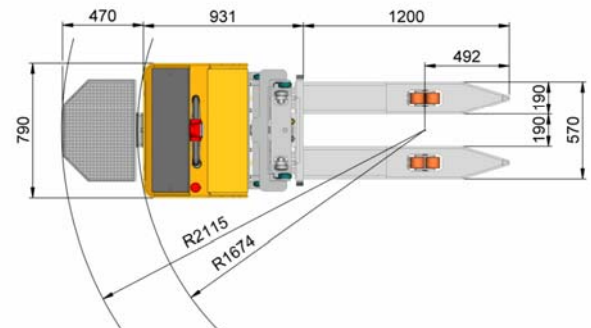
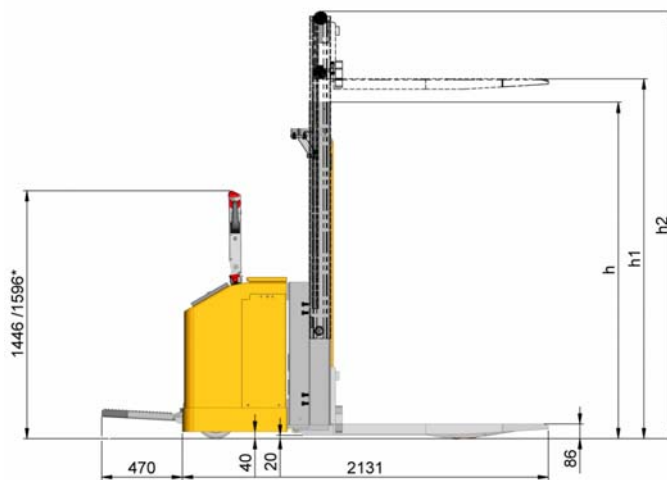

*Without platform

These specifications are subject to change without notice

Electric pallet stacker

SBE/SIR 92 T Capacity 1500kg
Stainless, Triplex and initial lift

Walsted Truck A/S

Flexible solutions

- Two wheel drive
- Power steering
- With or without side guards / stand-in
- With or without stand-on platform
- Can also be supplied in painted versions

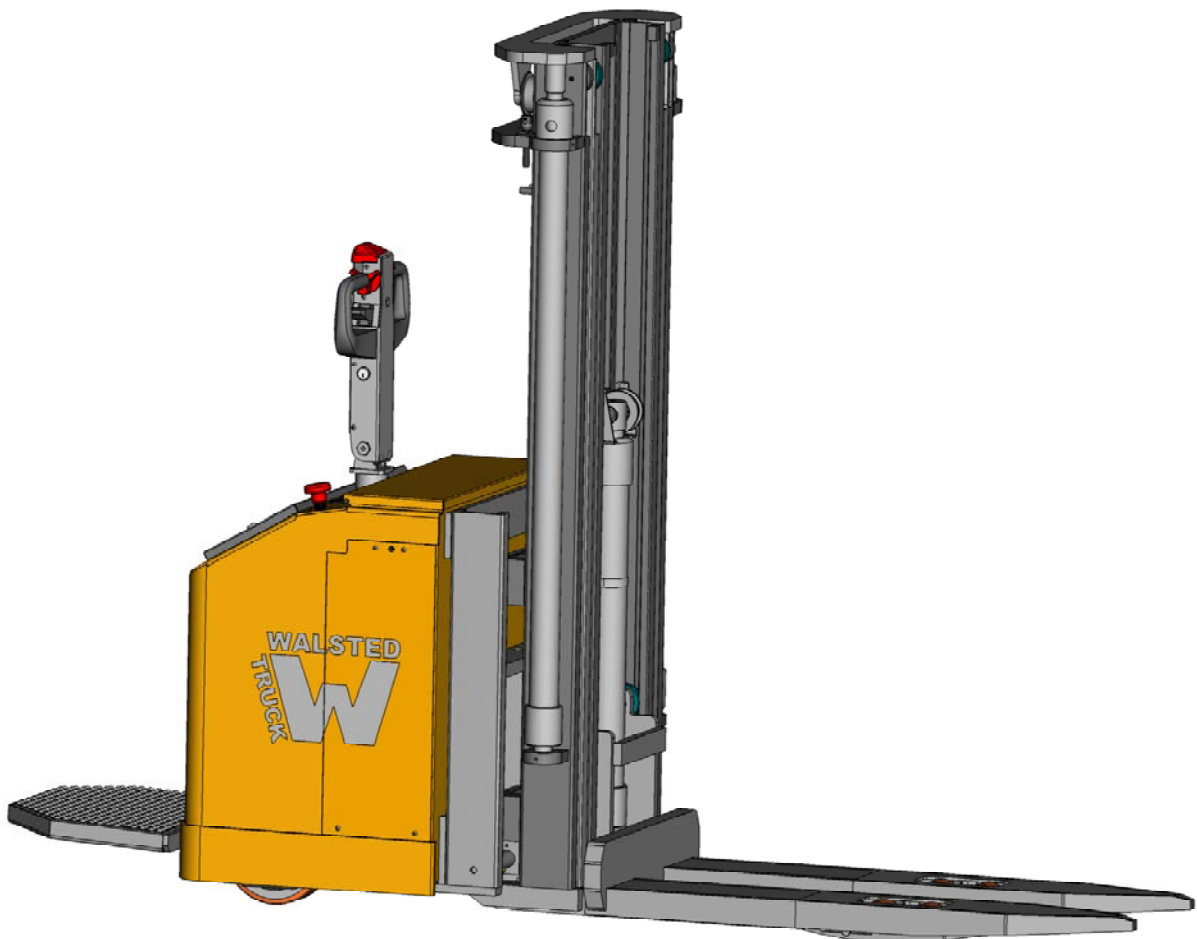

SBE/SIR 92 T Specifications

Stainless, triplex and initial lift

Walsted Truck A/S

Flexible solutions

Type			SBE/SIR 92 T
Max lifting load	Total load on forks + Basislift	kg	2000
Capacity, forks	Q load by 600mm loadcenter	kg	1500
Capacity, basislift		kg	2000
Liftingheight, basislift	Up to 2500mm lift	mm	200
Power type	Electric (battery)		Battery
Type of steering	Electric power steering		
Forkwheels	Numbers / type V = Vulkollan		(4x) / V
Drivingwheels	Numbers / type V = Vulkollan		(2x) / V
Turning radius	Wa (without platform)	mm	1674
Turning radius	Wa (with platform)	mm	2115
Aisle width	AST with pallet 800 x 1200 (without platform)	mm	2366
Aisle width	AST with pallet 800 x 1200 (with platform)	mm	2807
Speed	Driving speed without/with load	km/h	6/5,4-(11,5/8,5**)
Grade ability	Without/with load	%	10/10
Weight	Without battery	kg	1150
Brakes	Type		Electric
Battery	Type		Reinforced
	Capacity by 5 hours	V/Ah	24/344
	Weight approx.	kg	262
Electric motors	Drivemotor power/S2 min.	KW/min.	2x1,5/60
	Pump motor power/S3	KW/%.	3/-
Speed control			Stepless
Lifting / lowering control	Electric		Stepless

** With side-guards

Masttype	h =Building-height (mm)	h1 = lift (mm)	h2=Buildingheight by max lift (mm)	Freelift (mm)	Capacity by 600mm L/C(kg)
Triplex	1716	3500	3897	1264	1200
	1882	4000	4397	1430	800
	1949	4200	4597	1497	750
	2016	4400	4797	1564	700

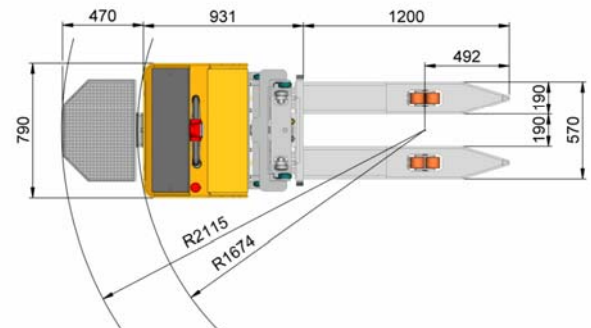
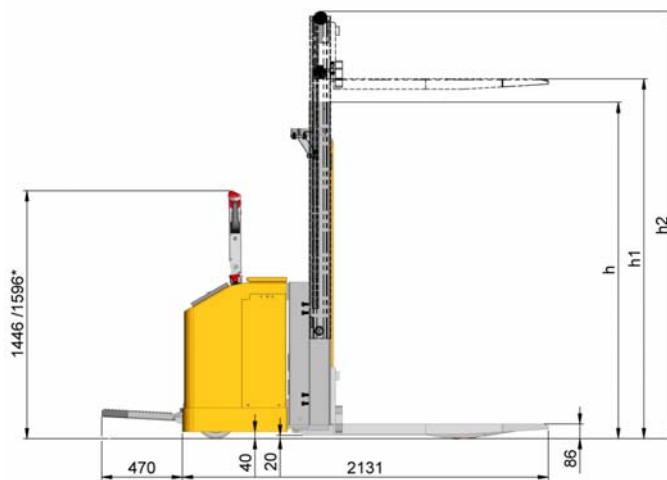

*Without platform

These specifications are subject to change without notice

Electric pallet truck

EHLR 95 Capacity 2500kg
Stainless version

Walsted Truck A/S

Flexible solutions

- Two wheel drive
- Power steering
- With or without side guards / stand-in
- With or without stand-on platform
- Can also be supplied in painted versions



EHLR 95 Specifications.

Stainless

Walsted Truck A/S

Flexible solutions

Type			EHLR 95
Capacity	Q Load	kg	2500
Powertype	Electric (battery)		Battery
Controltype	Electric powersteering		Walking/standing
Tyre equipment	Number / V =Solid tyre		(2 or 4x) / V
Wheels	Number / type V=Solid tyre		(2x) / V
Turning radius	Wa (- platform)	mm	1821
Turning radius	Wa (+ platform)	mm	2265
Aisle width	AST For pallet 800 x 1200 (- platform)	mm	2198
Aisle width	AST For pallet 800 x 1200 (+ platform)	mm	2640
Speeds	Driving speed without/with load	km/h	6/5,4-(11,5/8,5**)
Gardability	Without/with load	%	10/10
Weight	Excl. battery	kg	600
Brakes	Type		Electric
Parkingbrake	Type		Electric
Battery	Type		Reinforced
		V/Ah	24/344
	Approx. weight	kg	262
Drive motor	Drive motor power /S2 min.	KW/min.	2x1,5/60
	Pump motor power/S3	KW/%.	2,2/-
Speed control			Variable

This specifications are subject to change without notice.

** With side guards

*Without platform.

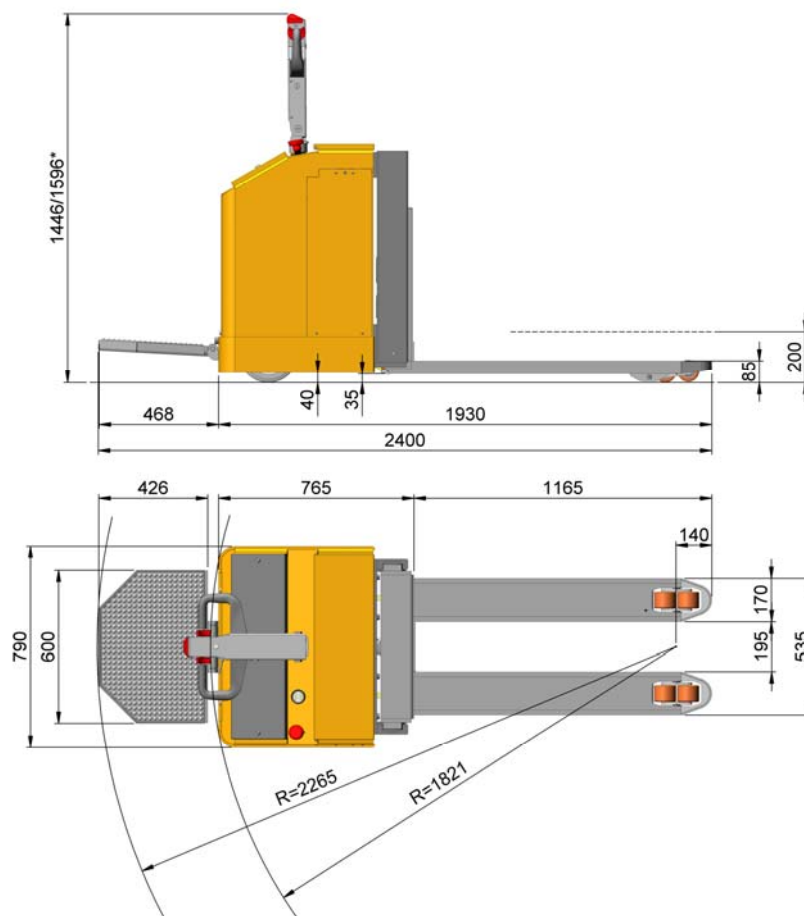

Electric pallet stacker

SBE/SFR Capacity 1500kg
Stainless

Walsted Truck A/S

Flexible solutions

- **With or without power steering**
- **Infinite transistor controlled.**
- **High reliability.**
- **Available with special fork length / width**
- **Can also be supplied in painted versions**



SBE/SFR Specifications

Stainless

Walsted Truck A/S

Flexible solutions

Model		SBE/SFR 1000	SBE/SFR 1500	
Capacity	Q load	kg	1000	1500
Loadcentre	C distance	mm	600	600
Power type	Elektric (battery)	Battery	Battery	
Control type		Standing	Standing	
Tire equipment	V=Solid tire	Front/rear	V/V	V/V
Wheels (x=Driven)	Number	Front/rear	4/(1x)1	4/(1x)1
Forktype		Permanent	Permanent	
Fork dimensions	S Thickness	mm	90	90
(Standard)	F Fork width	mm	180	180
	L3 Fork length	mm	1200	1200
	L2 Length to face of forks	mm	880	880
Overall dimensions	L Length truck	mm	2080	2080
	h Truck height	mm	2265	2265
	B Width	mm	880	880
	B3 Width external forks	mm	555	555
Turning radius	Wa	mm	1756	1756
Aisle width	AST For pallet 800 x 1200	mm	2150	2150
Speeds	Driving speed without/with load	km/h	8,5/7,5	8,5/7,5
	Lift speed without/with load	m/sek.	0,3/0,18	0,3/0,16
	Lowering speed without/with load	sek.	Infinitely variable	Infinitely variable
Gradeability	Without/with load	%	12/8	12/8
Weight	Without. battery	kg	1180	1180
Axle loading	With load front/rear	kg	1380/866	1850/900
Wheel size	Front	mm	ø85x65	ø85x65
	Rear	mm	ø300x90/ ø125x100	ø300x90/ ø125x100
Wheel base	y	mm	1450	1450
Tread	Centre tire front/rear	mm	375/565	375/565
Ground clearance	With load	mm	30	30
Brakes	Foot pedal brake		Elektro-magnetic	Elektro-magnetic
	Parking brake		Elektro-magnetic	Elektro-magnetic
Battery	Type		Rinforced	Rinforced
	V/Ah		24/189-270	24/189-270
	Weight	kg	215-252	215-252
Electric motor	Drive motor power/S2 min.	KW/min.	2,1/60	2,1/60
	Pump motor power/S3	KW/%.	3/20	3/8
Speed control	Type, turn - pedal		Turn	Turn
	Number of speed		Infinitely variable	Infinitely variable
Transmission	Type		Gears	Gears
Equipment	Max pressure	atm	90	130

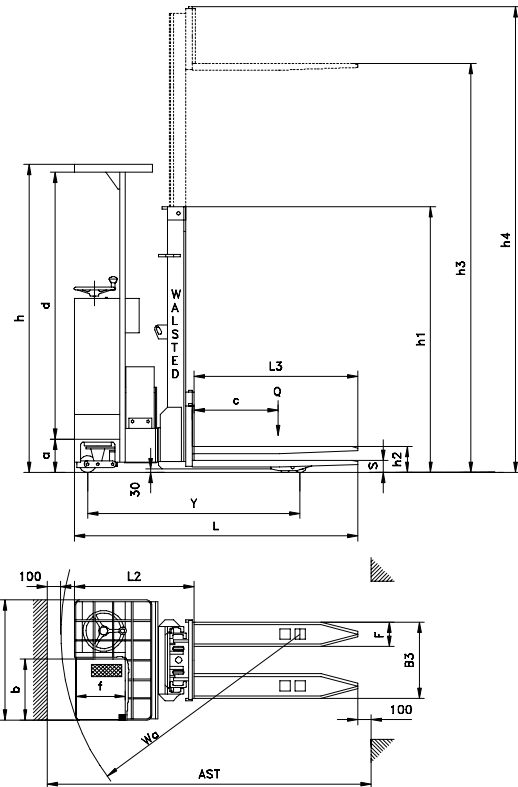

These specifications are for truck with duplexmast.
This specifications are subject to change without notice.

Driver's stand	a mm	b mm	d mm	f mm	
	260	440	1935	360	
Standard lift heights with simplex mast					
h3 lift height	h4 mast height	h1 mast height	h2 free lift	SBE/SFR 1000	SBE/SFR 1500
mm	mm	mm	mm	Capacity kg	Capacity kg
2000	2415	2380	1965	1000	1500
Standard lift heights with duplex mast					
3500	3950	2200	190	800	800
3000	3450	1950	190	1000	1000
2500	2950	1700	190	1000	1500
2000	2450	1450	190	1000	1500

Can be delivered with special lift heights.

Electric pallet truck

EHLFRK Capacity 2500kg
Stainless

Walsted Truck A/S

Flexible solutions

- With or without power steering
- Infinite transistor controlled.
- High reliability.
- Available with special fork length / width
- Can also be supplied in painted versions



EHLFRK specifications

Stainless

Walsted Truck A/S

Flexible solutions

Specifications:

Model		EHLF 12	EHLF 25
Capacity	Q load kg	1200	2500
Loadcentre	C distance mm	600	600
Power type	Elektric (battery)	Battery	Battery
Control type		standing	standing
Tire equipment	V=Solid tire Front/rear	V/V	V/V
Wheels (x=Driven)	Number Front/rear	4/(1x)1	4/(1x)1
Lift	h3 Lift mm	120	120
Forktype	Permanent	Permanent	Permanent
Fork dimensions	S Thickness mm	85	85
(Standard)	F Fork width mm	170	170
	L3 Fork length mm	1165	1165
	L2 Length to face of forks mm	765*	765*
Overall dimensions	L Length truck mm	1930*	1930*
	B Width mm	880	880
	B3 Width external forks mm	535	535
Drivers stand	a Height mm	260	260
	b Width mm	440	440
	f Depth mm	360	360
Turning radius	Wa mm	1907*	1907*
Aisle width	AST For pallet 800 x 1200 mm	2257*	2257*
Speeds	Driving speed without/with load km/h	8,5/7,5	8,5/7,5
	Lift speed without/with load Sek.	3/4	3/5
	Lowering speed without/with load Sek.	4/3	4/3
Gradeability	Without/with load %	15/8	15/8
Weight	Without. battery kg	550	550
Axle loading	With load front/rear kg	1007/809	1995/1571
Wheel size	Front mm	ø85x65	ø85x65
	Rear mm	ø300x90/ ø125x100	ø300x90/ ø125x100
Wheel base	y mm	1500	1500
Tread	Centre tire front/rear mm	630/380	630/380
Ground clearance	With load mm	36	36
Brakes	Foot pedal brake	Elektromagnetic	Elektromagnetic
	Parking brake	Elektromagnetic	Elektromagnetic
Battery	Type	Rinforced	Rinforced
	V/Ah	24/200 - 258	24/200 - 258
	Weight kg	160 - 218	160 - 218
Electric motor	Drive motor power/S2 min. KW/min.	2,1/60	2,1/60
	Pump motor power/S3 KW/%.	2,5/15,5	2,5/8
Speed control	Type, turn - pedal	Turn	Turn
	Number of speed	3/3 or infinitely variable	3/3 or infinitely variable
Transmission	Type	Gears	Gears
Equipment	Max pressure atm	65	105

